

NV1Q Opto-Keayer

TITLE
Keayer Assembly - Top View

SCALE	1:1	REV	1	DATE	2019-02-03	SHEET	1 of 7
-------	-----	-----	---	------	------------	-------	--------

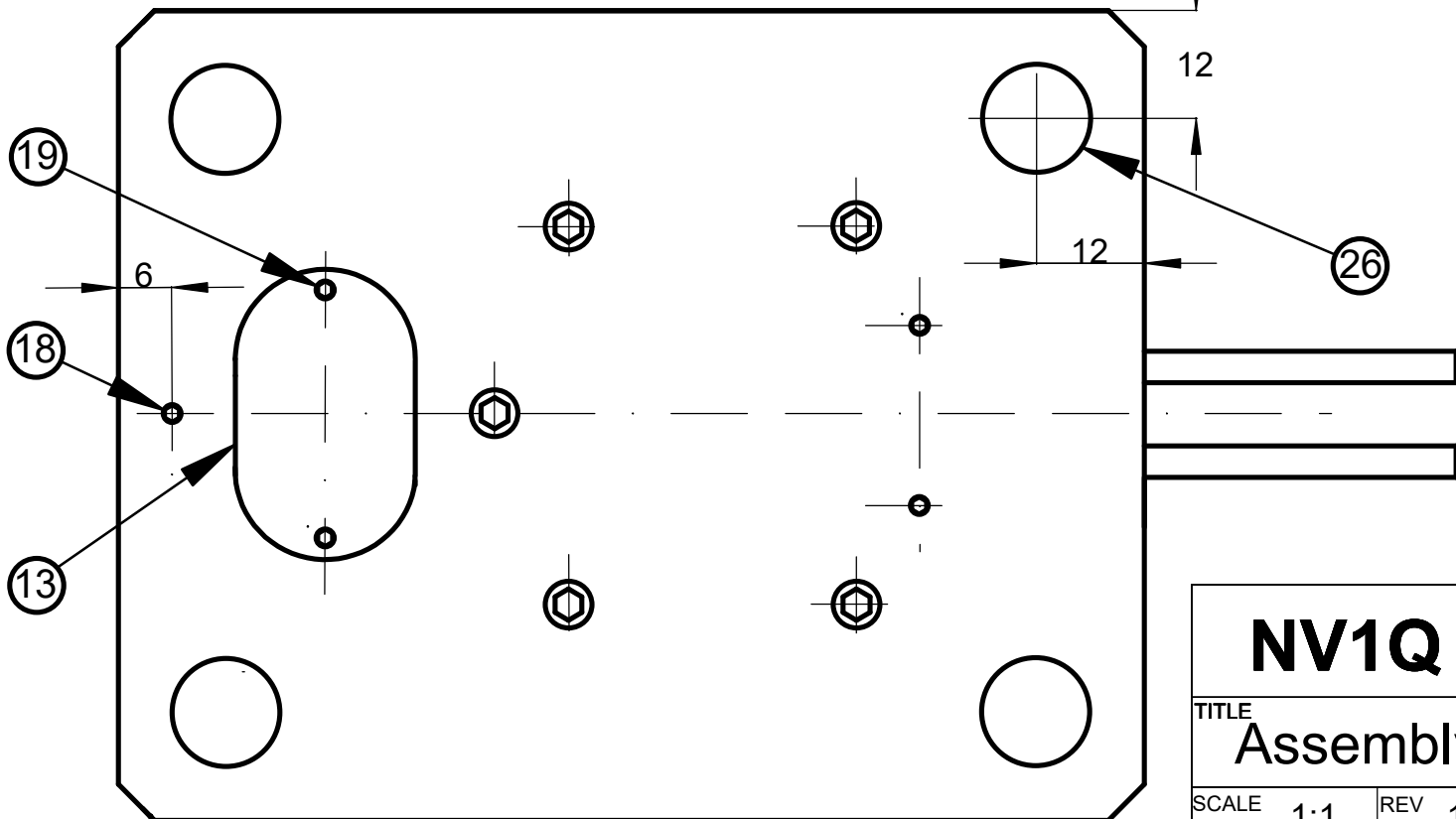
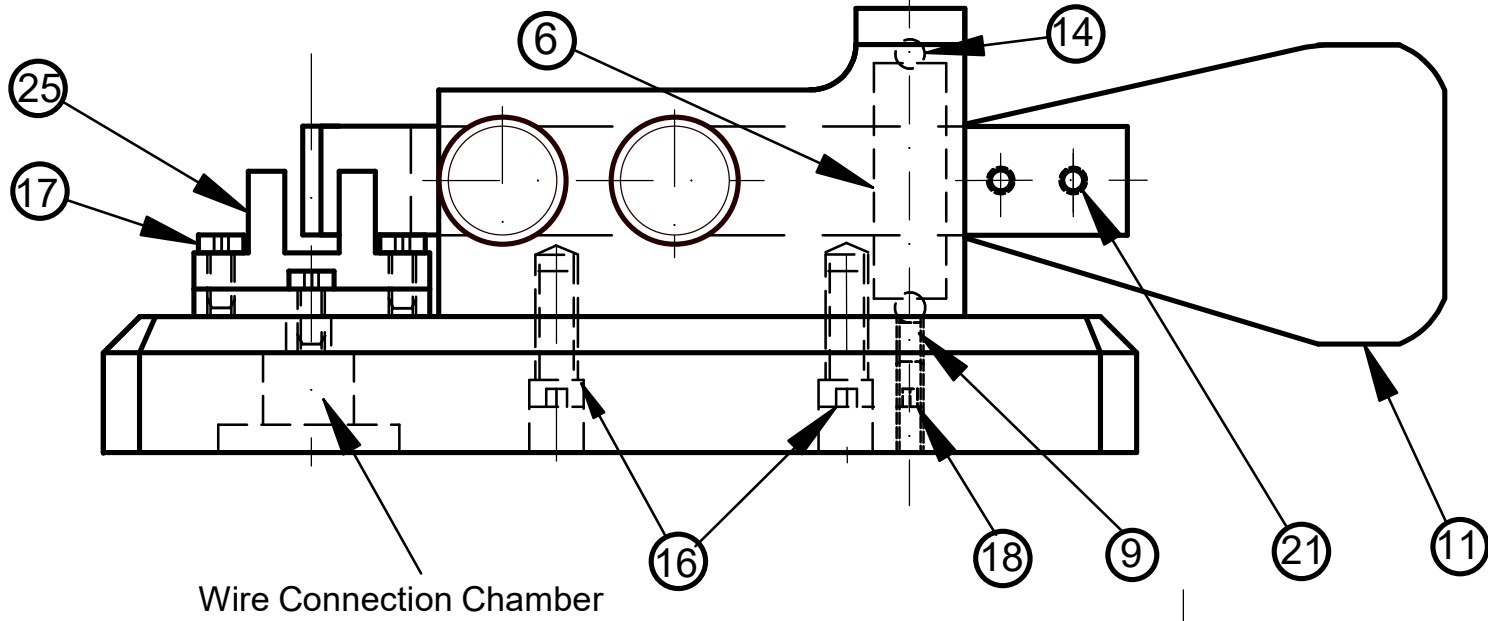

NV1Q Opto-Keyer

TITLE
Assembly - Side & Bottom

SCALE 1:1	REV 1	DATE 2019-02-03	SHEET 2 of 7
-----------	-------	-----------------	--------------

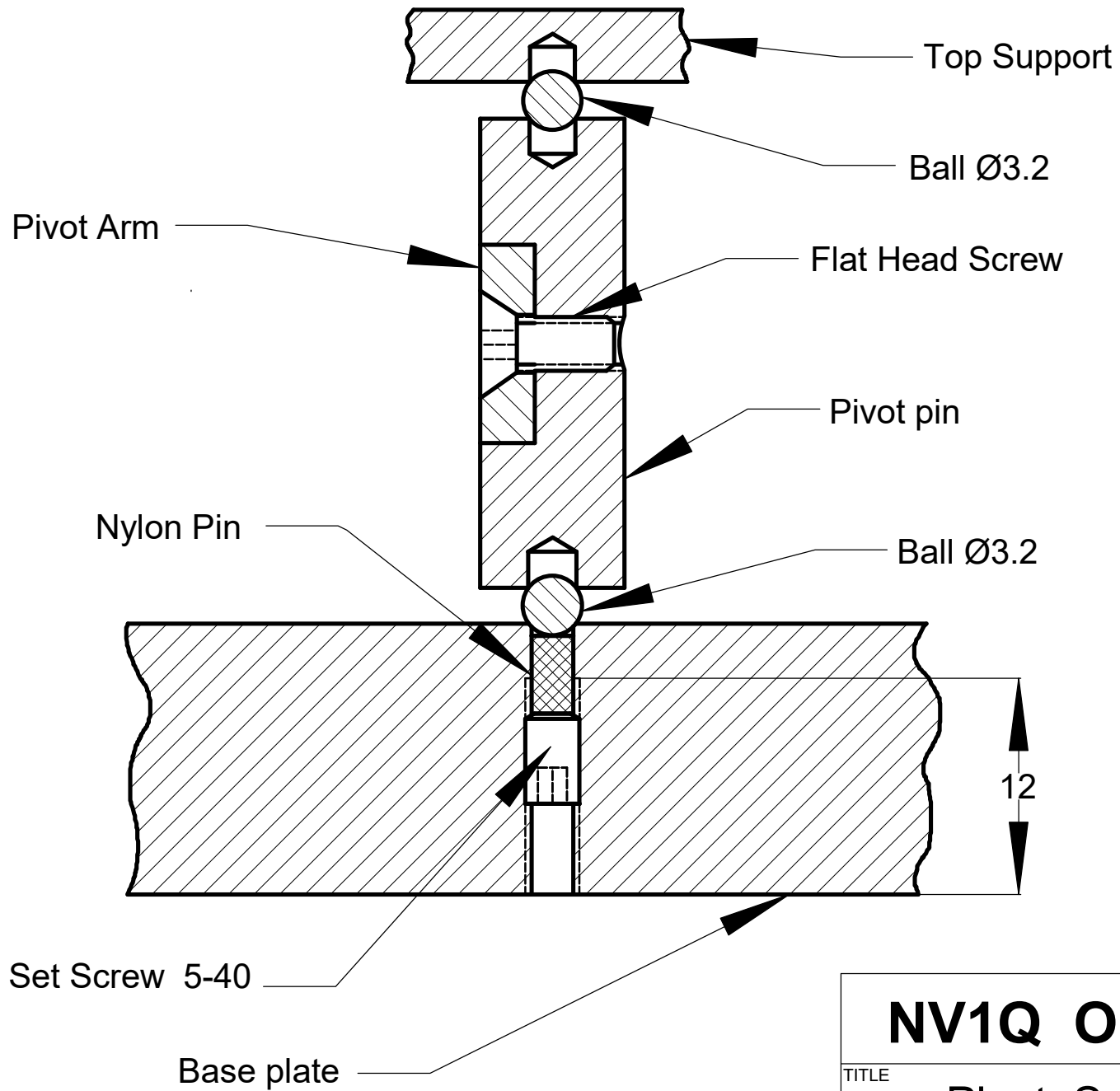

NV1Q Opto-Keayer

TITLE

Pivot Section A-A

SCALE 3:1

REV 1

DATE 2019-02-03

SHEET 3 of 7

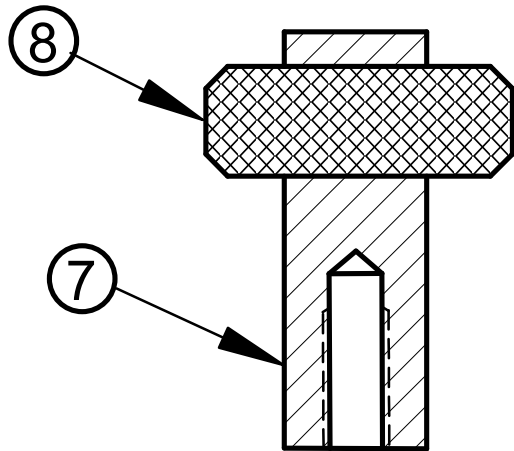

Part 8 (Stop Pin) pressed into part 7 (Pillar Block)

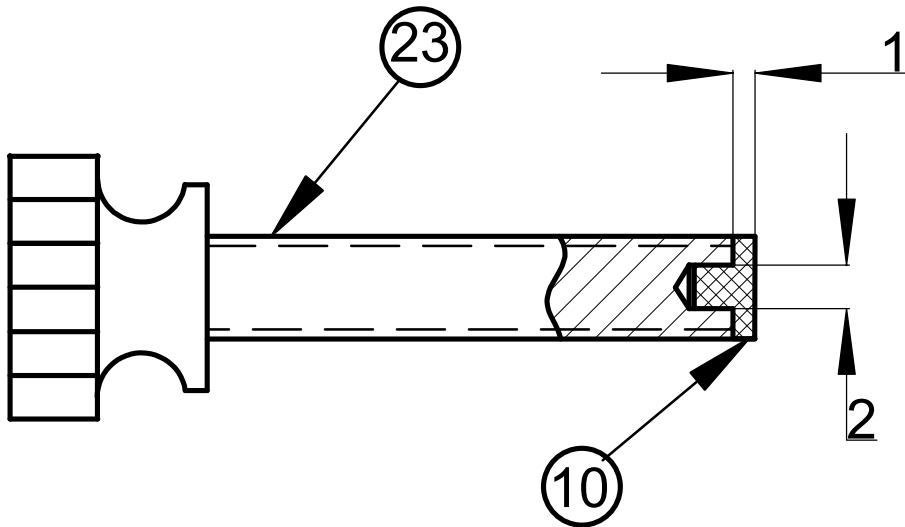

Part 10 (Screw Stop) pressed into part 23 (Screw)

Note: Applying a Nylon stop to the screw is not required, but it provides a smoother non-clicking sound.

NV1Q Opto-Keyer

TITLE

Nylon Stops

SCALE

3:1

REV

1

DATE

2019-02-03

SHEET

4 of 7

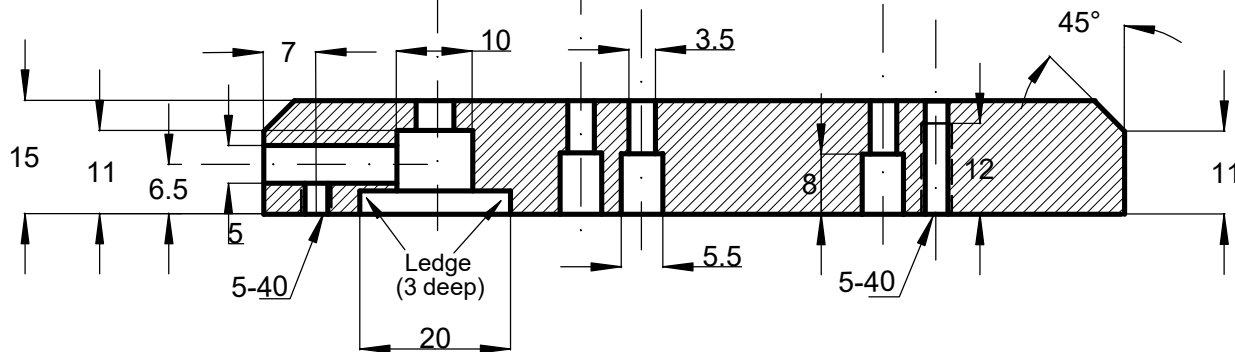
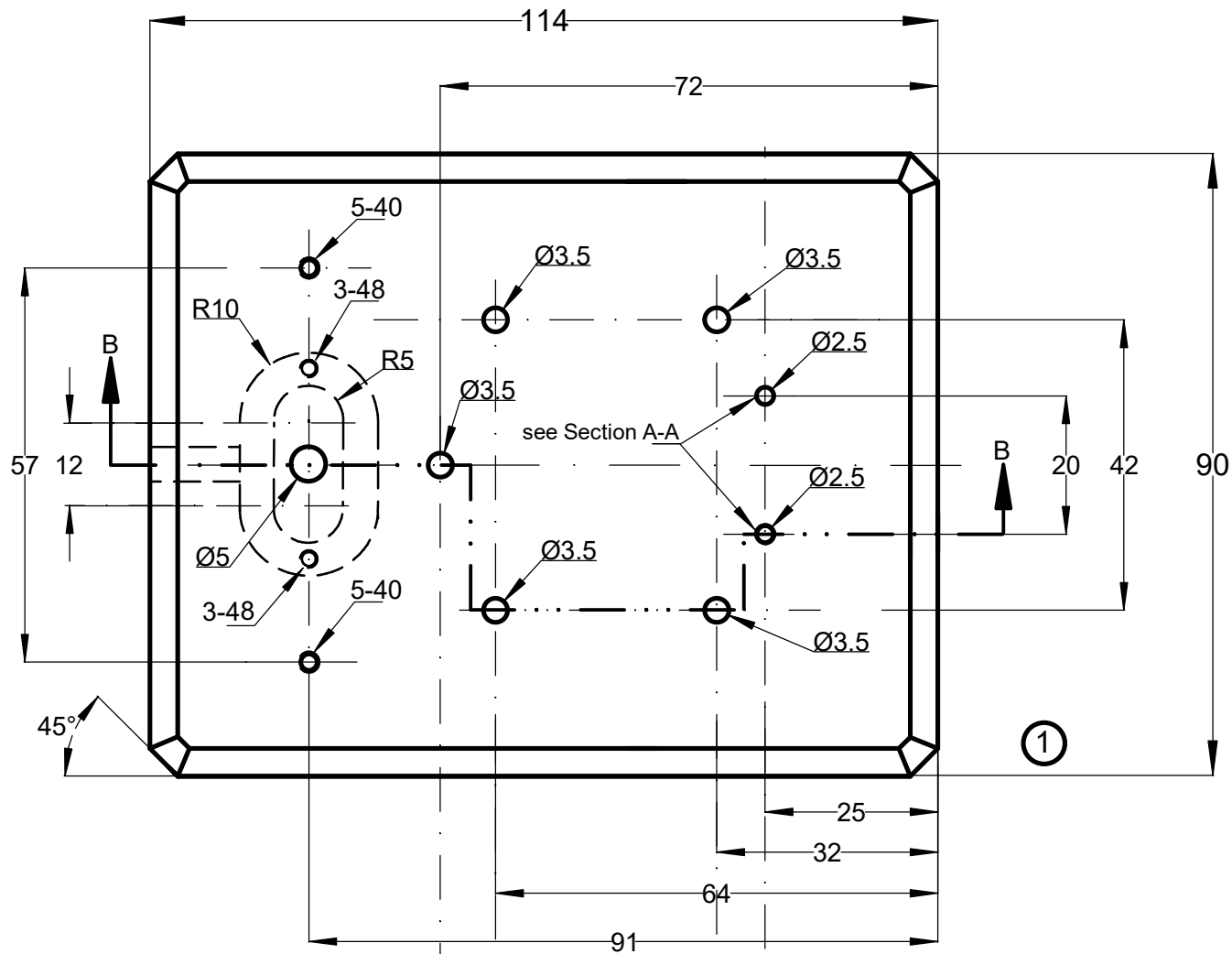

NV1Q Opto-Keyer

TITLE
Base

SCALE 1:1 REV 1 DATE 2019-02-03 SHEET 5 of 7

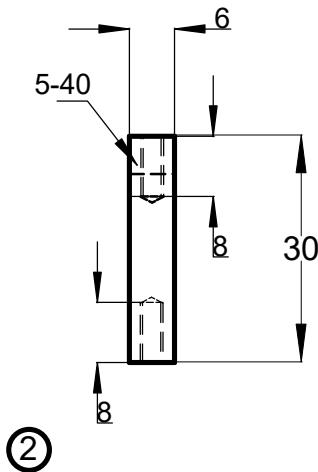
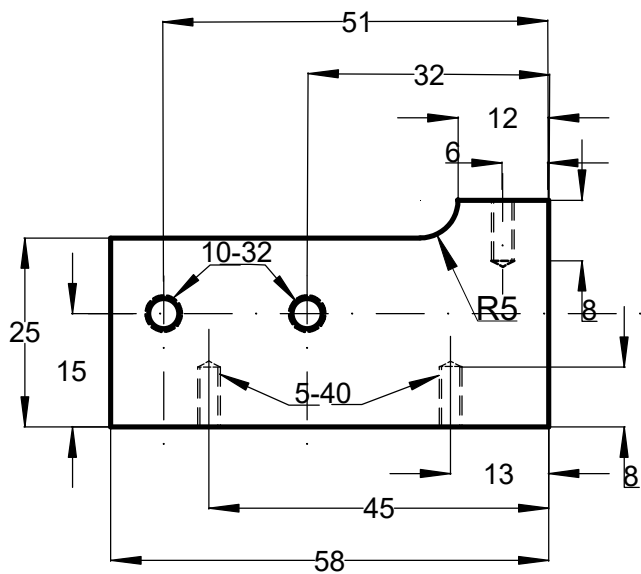
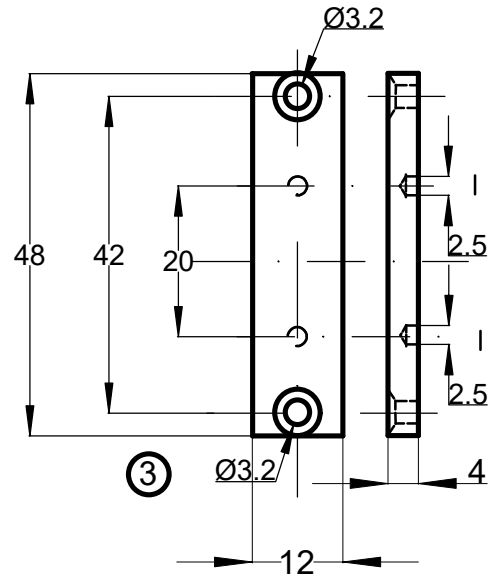
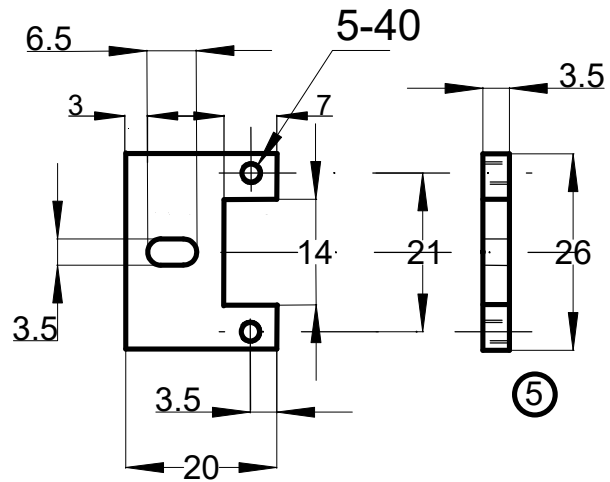

Part No.	Name	Qty
2	Lateral Support	2
3	Top Support	1
4	Pivot Arm	2
5	Switch Holder	2

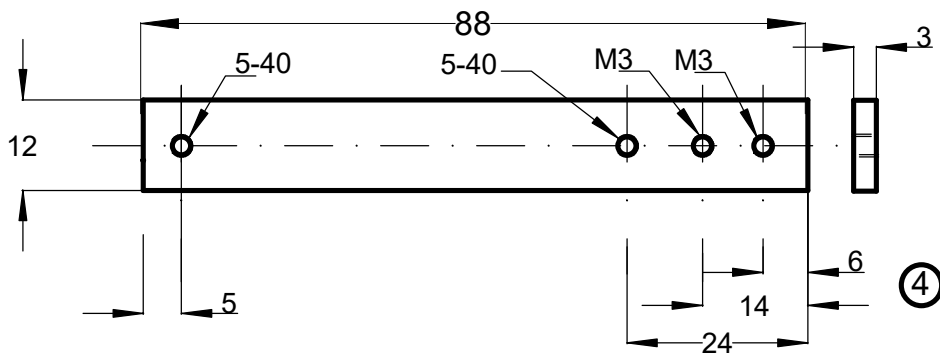

NV1Q Opto-Keyer

TITLE			
Parts DWG 1			
SCALE	REV	DATE	SHEET
1:1	1	2019-02-03	6 of 7

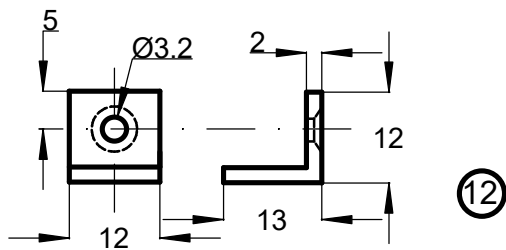
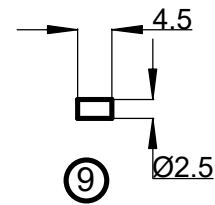
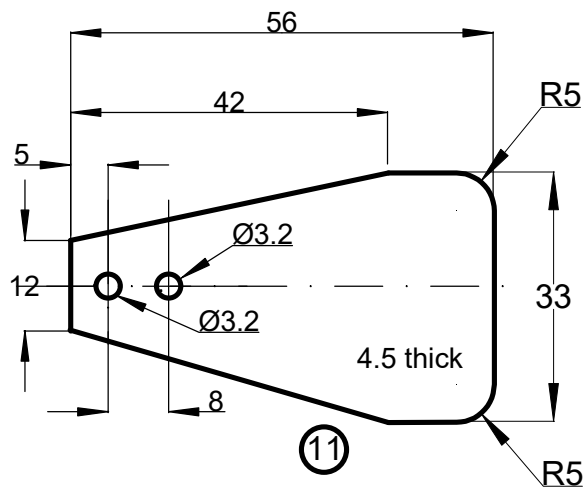
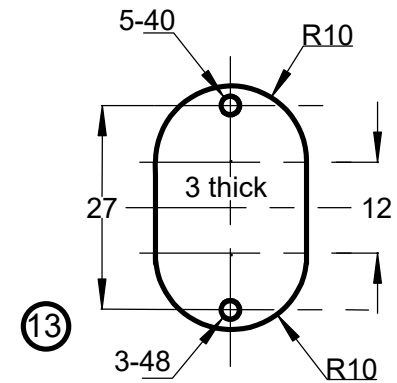
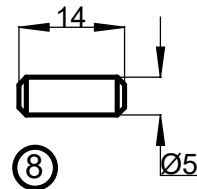
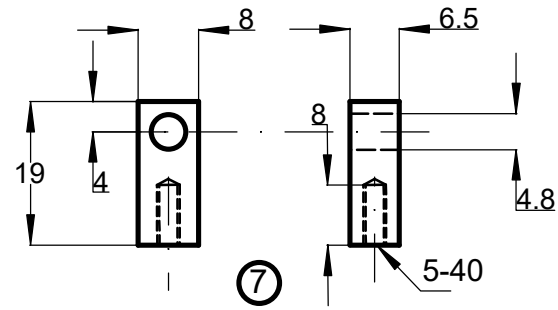
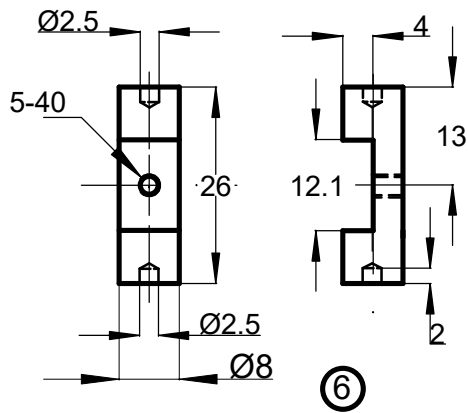

Part No.	Name	Qty
6	Pivot Pin	2
7	Stop Pillar	1
8	Stop Pin	2
9	Press Pin	2
11	Paddle	2
12	Corner Flag	2
13	Cover Plate	1

NV1Q Opto-Keyer

TITLE
Parts DWG 2

SCALE 1:1 REV 1 DATE 2019-02-03 SHEET 7 of 7

NV1Q Opto-Keyer – Parts List

Part No.	Name	Qty	Material	Vendor	Vendor Part No.
1	Base	1	Bronze	Metal Supermarkets	
2	Lateral support	2	Bronze	Metal Supermarkets	
3	Top Support	1	Bronze	Metal Supermarkets	
4	Pivot Arm	2	Bronze	Metal Supermarkets	
5	Sliding Plate	2	Bronze	Metal Supermarkets	
6	Pivot Pin	2	Bronze	Metal Supermarkets	
7	Stop Pillar	1	Bronze	Metal Supermarkets	
8	Stop Pin	1	Nylon	ACM Plastics	
9	Press Pin	2	Nylon	ACM Plastics	
10	Screw Stop	2	Nylon	ACM Plastics	
11	Paddle	2	Acrylic	ACM Plastics	
12	Corner Flag	2	Rigid Vinyl	Barbour Plastics	
13	Cover Plate	1	Brass	Metal Supermarkets	
14	Steel Ball	4	Steel	vxb.com Ball Bearings	
15	Spring	2		Home Depot	471864
16	Head Cap Screw #5-40 x 5/8	6	Steel	ASMC Industrial	0000-216773
17	Head Cap Screw #5-40 x 1/4	4	Steel	ASMC Industrial	0000-216770
18	Set Screw #5-40 x 1/4	3	Steel	ASMC Industrial	0000-100672
19	Set Screw #3-48 x 1/4	2	Steel	ASMC Industrial	0000-100625
20	Flat Head Screw #5-40 x 1/4	6	Steel	ASMC Industrial	0000-101654
21	Button Head Cap Screw M3 x 6	4	Steel	ASMC Industrial	0000-101290
22	Knurled Thumb Screw #10-32 x 3/4	2	Brass	Albany County Fasteners	1018-10003-0038
23	Knurled Thumb Screw #10-32 x 1	2	Brass	Albany County Fasteners	1018-10003-0050
24	Knurled Thumb Nut #10-32	4	Brass	Albany County Fasteners	122042
25	Slotted Optical Switch	2		Amazon	
26	Door Pumpers	4		Amazon	